

SBP2® Pendant Pushbutton Stations

Installation Instructions



MAGNETEK
MATERIAL HANDLING
ELECTROMOTIVE SYSTEMS

P.O. Box 13615
Milwaukee, WI 53213-3615

Phone: 262/783-3500
Fax: 262/783-3510

Toll free Phone (in USA): 800/288-8178
Toll free Fax (in USA): 800/298-3503

Part Number: 005-1053-R2
©2010 Magnetek



MAGNETEK
MATERIAL HANDLING
ELECTROMOTIVE SYSTEMS



WARNING

- Do not operate SBP2 Pendant Pushbutton Station unless you are fully trained and qualified to operate the overhead material handling system of which this SBP2 is a component. For applications other than overhead cranes or hoists, consult Electromotive Systems at 1-800-288-8178.
- Read the entire contents of this manual before you install or use the SBP2 Pendant Pushbutton Station.



CAUTION

Prior to installation, inspection, or repair of pendant station, disconnect power at source following lockout/ tagout procedures as outlined in ANSI Z244.1.

If the pendant cable grip is not properly sized to fit the pendant cable, contamination of the pendant housing is possible. Contaminants which enter the switch contacts may result in a potentially unsafe operating condition.

When cutting, stripping, and installing wires, ensure that contaminants do not fall into the enclosure. Contaminants which enter the switch contacts may result in a potentially unsafe operating condition.

Some pendant cable manufacturers add “talc” to their cable during the manufacturing process. This “talc” can migrate from the cable into the housing of the pendant station. As a result, contamination of switch contacts may occur resulting in a potentially unsafe operating condition. Electromotive Systems therefore recommends only the use of “talc” free cable for the wiring of all pendant stations.

Remove all contaminants from the housing and switch contact areas prior to sealing the enclosure and putting the pendant in service.

©2010 Magnetek

All rights reserved. This notice applies to all copyrighted material included with this product, including, but not limited to, this manual and software embodied with in the product. This manual is intended for the sole use of the persons to whom it was provided, and any unauthorized distribution of the manual or dispersal of its contents is strictly forbidden. This manual may not be reproduced in whole or in part by any means whatsoever without the expressed written permission of Magnetek.

DISCLAIMER OF WARRANTY

Magnetek, hereafter referred to as Company, assumes no responsibility for improper use of supplied product by untrained personnel. Product should only be installed or repaired by a trained technician who has read and understands the contents of this manual. Improper installation or service can lead to unexpected, undesirable, or unsafe operation or performance. This may result in damage to equipment or personal injury. Company shall not be liable for economic loss, property damage, or other consequential damages or physical injury sustained by the purchaser or by any third party as a result of such operation or service. Company neither assumes nor authorizes any other person to assume for Company any other liability in connection with the sales or use of this product. For information on Magnetek’s product warranties by product type, please visit www.magnetekmh.com.

Replacement Parts

Description	Catalog #
Single Speed 2-Button Switch	SBP2-A2
Single Speed 2-Button Switch (N.O./N.C. per button)	SBP2-
AB2	
Single Speed 2-Button Switch (Each button with two N.O. Contacts)	SBP2-D2
Two-Speed 2-Button Switch	SBP2-S
Three-Speed 2-Button Switch	SBP2-T
Momentary On/Off 2-Button Switch	SBP2-B
Maintained On/Off 2-Button Switch	SBP2-H2
Maintained On/Off (N.O./N.C.) 2-Button Switch	SBP2-H3
Button Cover Black for Single-, Two, Three-Speed Switches	WC2-LB
Button Cover – Red for On/Off Switches	WC2-R
Button Cover – Green for On/Off Switches	WC2-G
Button Cover – Black Oil Resistant	WC2-BS
Legend Sheet for Button Covers	004-1060
2-Button Enclosure	SBP2-E2
4-Button Enclosure	SBP2-E4
6-Button Enclosure	SBP2-E6
8-Button Enclosure	SBP2-E8
10-Button Enclosure	SBP2-E10
12-Button Enclosure	SBP2-E12
Top Assembly 3/4" NPT	SBP2-TA1
Top Assembly 1" NPT	SBP2-TA2
Screws for Enclosure	009-4007
Switch Gasket	004-7280

Accessories

Description	Catalog #
2 Position Selector Switch	SBP2-L2
3 Position Selector Switch N.C. in Center	SBP2-L3
3 Position Selector Switch N.O. in Center	SBP2-L3B
120 Volt Red Pilot Light-Mounts in Standard Button Hole	SBP2-PLX-R
120 Volt Green Pilot Light-Mounts in Standard Button Hole	SBP2-PLX-G
120 Volt White Pilot Light-Mounts in Standard Button Hole	SBP2-PLX-W
120 Volt Yellow Pilot Light-Mounts in Standard Button Hole	SBP2-PLX-Y
Red Mushroom On/Off Switch-Turn to Release for On	SBP2-SMMH
Blank to Cover Button Hole	SBP2-BLNK
Cable Grip Kit*	CG-KIT

*Kit Includes nut, washer and six grommets.

Installing and Wiring SBP2® Pendant Pushbutton Station

Precautions at Installation

- Do not expose the unit to cold blasts of air that might cause condensation (e.g., air conditioning duct).
- Do not expose the unit to cleaning solvents that will penetrate and damage the unit's enclosure.
- Do not use cable which is split or cracked.
- Whenever possible assemble the pendant in a verticle position to avoid contaminates falling into the enclosure.
- Attach the pushbutton station to the strain relief cable so that no tension is exerted on the pushbutton cable directly.



DANGER

HIGH VOLTAGES ARE PRESENT IN THE CONTROL PANEL, JUNCTION BOXES, PENDANT'S ELECTRICAL COMPONENTS AND THE CONNECTION BETWEEN THESE COMPONENTS.

Before installing, servicing or inspecting any electrical or mechanical components of this power equipment, power must be disconnected at the source and proper lockout/tagout procedures followed.

DO NOT make or break electrical connections (example, plugs and receptacles) without first disconnecting power at the source and following proper lockout/tagout procedures.

REFER TO ANSI Z244.1 PERSONNEL PROTECTION – LOCKOUT/TAGOUT OF ENERGY SOURCES.

Only qualified personnel should install components, inspect and/or service this equipment.

Precautions at Wiring

- If the cord grip on the top of the pendant does not fit the cable properly, water or dust may penetrate through the cable grip and cause damage to the buttons or cause the cranes and hoists to function improperly.
- When cutting or stripping wires, ensure that particles do not fall into the pendant enclosure.
- Use a UL Listed round crimp-style terminal when connecting the wiring terminal. Do not solder the terminal or connect the bare wires directly.

Enclosure Disassembly

1. Unscrew pendant cable grip nut.
2. Remove the top cover by loosening its two screws.
3. Remove the back cover by loosening the enclosure screws.

Pendant Control Cable Installation

Note:

Electromotive Systems recommends the use of a suitable outdoor rated and oil resistant pendant cable that is both UL Listed and CSA recognized.

When cutting or stripping wires, ensure that particles do not fall into the enclosure.

1. Feed the cable through the cable grip nut, compression washer, cable gland grommet, pendant top gasket, pendant top and enclosure until the cable extends along the entire enclosure length. Then hand tighten pendant top unit.
2. For ease of cable installation, attach the pendant top to the pendant enclosure front half leaving the back off and exposing the switches.
3. Strip back the cable outer jacket to within one inch of the top of the enclosure.
4. Cut, strip, and terminate each cable conductor.
Note: Use a provided or UL Listed closed loop or forked type terminal lug.
5. Fasten each cable conductor to its respective terminal screw. (Refer to wiring and marking information on page 12 of this manual.)
6. Code the opposite ends of the cable conductors to ensure proper wiring.

Parts List

	Description	Catalog #
2-Button	2-Button On/Off	SBP2-2-WB
	2-Button All Single Speed	SBP2-2-WA
	2-Button All Two-Speed	SBP2-2-WS
	2-Button All Three-Speed	SBP2-2-WT
4-Button	4-Button-(2) Single-Speed with On/Off	SBP2-4-WB
	4-Button-(2) Two-Speed with On/Off	SBP2-4-WBS
	4-Button- All Single-Speed	SBP2-4-WA
	4-Button- All Two-Speed	SBP2-4-WS
	4-Button- All Three-Speed	SBP2-4-WT
6-Button	6-Button-(4) Single-Speed with On/Off	SBP2-6-WB
	6-Button-(4) Two-Speed with On/Off	SBP2-6-WBS
	6-Button-(4) Three-Speed with On/Off	SBP2-6-WBT
	6-Button- All Single-Speed	SBP2-6-WA
	6-Button- All Two-Speed	SBP2-6-WS
	6-Button- All Three-Speed	SBP2-6-WT
8-Button	8-Button-(6) Single-Speed with On/Off	SBP2-8-WB
	8-Button-(6) Two-Speed with On/Off	SBP2-8-WBS
	8-Button-(6) Three-Speed with On/Off	SBP2-8-WBT
	8-Button- All Single-Speed	SBP2-8-WA
	8-Button- All Two-Speed	SBP2-8-WS
	8-Button- All Three-Speed	SBP2-8-WT
10-Button	10-Button-(8) Single-Speed with On/Off	SBP2-10-WB
	10-Button-(8) Two-Speed with On/Off	SBP2-10-WBS
	10-Button-(8) Three-Speed with On/Off	SBP2-10-WBT
	10-Button- All Single-Speed	SBP2-10-WA
	10-Button- All Two-Speed	SBP2-10-WS
	10-Button- All Three-Speed	SBP2-10-WT
12-Button	12-Button-(10) Single-Speed with On/Off	SBP2-12-WB
	12-Button-(10) Two-Speed with On/Off	SBP2-12-WBS
	12-Button-(10) Three-Speed with On/Off	SBP2-12-WBT
	12-Button- All Single-Speed	SBP2-12-WA
	12-Button- All Two-Speed	SBP2-12-WS
	12-Button- All Three-Speed	SBP2-12-WT

Wiring and Marking Information

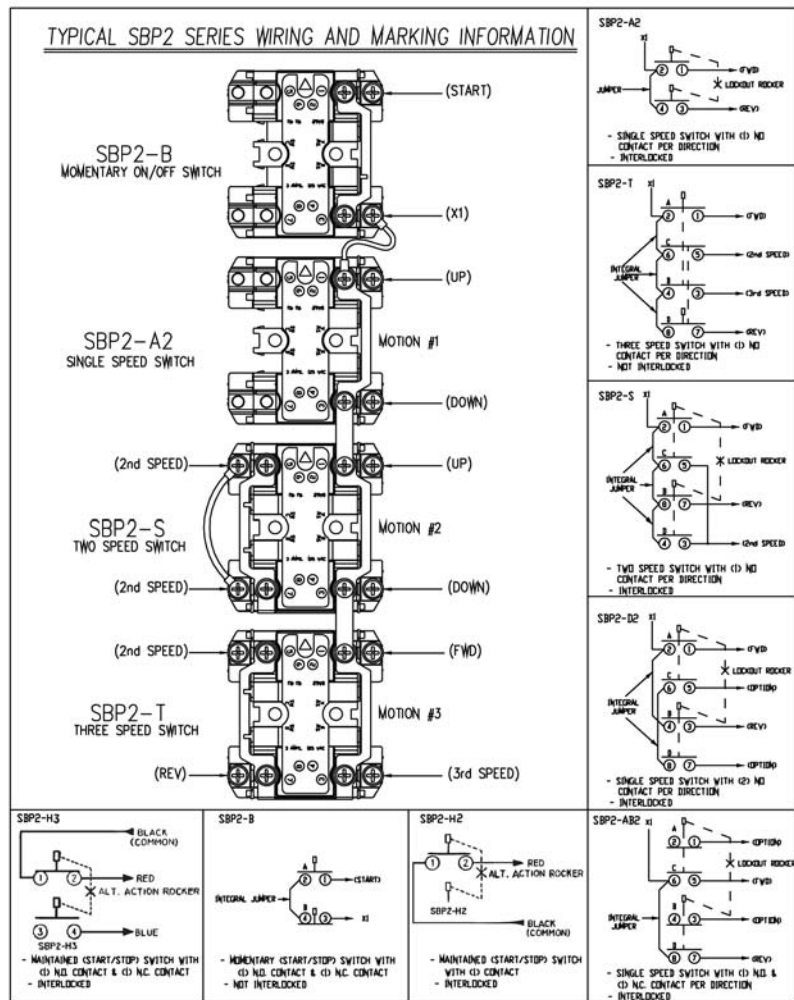

Pendants are supplied with a cord grip nut, compression ring and six cable grommets. See below for grommet sizing.

Cable Diameter

Grommet

.375"-.437"	00-4987
.437"-.562"	00-4980
.500"-.625"	00-4981
.562"-.687"	00-4982
.625"-.750"	00-4983
.687"-.812"	00-4984

Enclosure Reassembly



WARNING

When tightening enclosure screws do not exceed 9 inch pounds of torque. Overtorquing enclosure screws may cause damage to the enclosure.

1. Ensure that there are no bare cable conductor strands and that all conductors are insulated from each other.
2. Make sure that the enclosure water seal is properly placed in the groove of the front cover.
3. Reattach the back cover while carefully keeping the cable conductors inside the enclosure wiring area. Tighten the enclosure assembly screws.
4. Reinstall pendant top and top gasket. Tighten top screws.
5. Tighten pendant cable grip nut until cable is sealed and secure.
6. Install pendant strain relief split rings and strain relief cables if applicable.

Removing the Button Cover and Nameplate Insert

1. Using a small screwdriver, pry out the plastic nameplate insert.
2. Press one side of the nameplate insert into one side of the rubber button cover, and pry the button cover side to wedge in the plastic nameplate insert.
3. Remove the button cover (boot) only after the enclosure is disassembled and the switch is removed from the enclosure. Then press out (using a small screwdriver), the nylon retaining ring, which secures the button cover in the enclosure hole.
4. Snap the button cover into the enclosure hole from the front.

Assembly Drawing

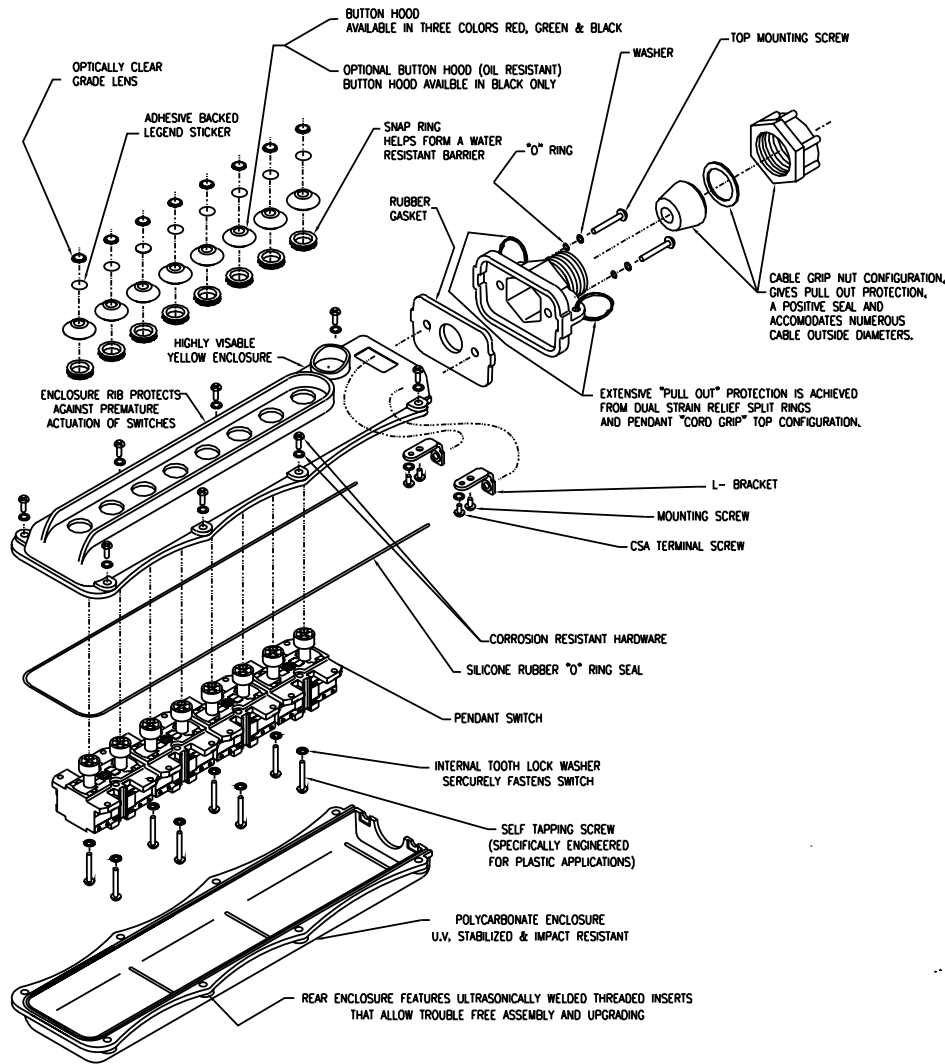

WARNING

- If cracks or other abnormalities are detected in any part, replace the part immediately. Failure to do so may cause the crane or hoist to function improperly.
- Replace a split or cracked enclosure, rain-proof button caps, cable armor, cable, or other parts immediately to prevent water from permeating the pushbutton enclosure which could cause an electrical shock or cause the crane and hoists to function improperly.

General Handling

- Do not place the pendant in a pool of water, or immerse it in water.
- Do not let the pendant slam into a hard object, wall, etc.
- Do not attempt to turn knobs or switches beyond their travel limits.



CAUTION

Do not operate equipment and/or pendant without switch gasket and label. Damaged switch gaskets and labels should be replaced to prevent contamination of the switch contacts. Call Electromotive Systems at 800/288-8178 for replacement gaskets and labels.

Switch Label

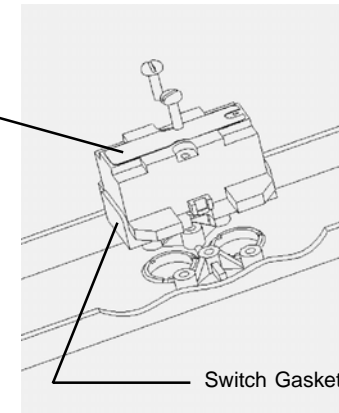

Switch Gasket

Wiring and Repair

- Use an approved round crimp-style terminal when wiring the terminals. Do not solder the terminal or connect the bare wires directly.
- Replace the cable if it is cracked or split.
- When cutting or stripping wires, ensure that particles do not fall into the enclosure.

Maintenance

- On a continual basis, ensure that the interlock mechanism is operating properly and that the buttons return to the off position when released.
- Inspect condition of pendant on a regular basis (dependant on duty cycle).

Safe Crane Operating Practices

- When moving a load with the crane, stand facing the suspended load; move the load away from you.
- Perform only one operation at a time.
- When you are not using the pendant station, hang the unit as shown on page 7; do not let it lay horizontally.
- If a problem occurs during the operation of the pushbutton station, stop operation immediately and contact the person in charge of maintenance. Prior to inspection or repair of the pendant station, disconnect power at source following lockout/tagout procedures as outlined in ANSI Z244.1.
- Check the enclosure and insulating material for any damage.

Environment

- Do not expose the unit to cold blasts or air that might cause condensation (e.g. air conditioning duct).
- Do not expose the unit to cleaning solvents that will penetrate the unit's enclosure.

Operating SBP2 Pendant Pushbutton Station Safely

When using a pendant station, take the following precautions:

Pre-Operation Inspection

1. Ensure that the overall condition of the unit's exterior is sound.
2. Ensure that the buttons function normally (return to the off position when released) and are labeled properly for function.
3. Remove any dirt, sand, or moisture buildup.
4. Ensure the cable is not damaged.
5. Ensure that the strain relief wire supporting the cable is installed (if applicable).

The pendant station should be installed at a height of approximately 3'-6" from the ground, as shown below.

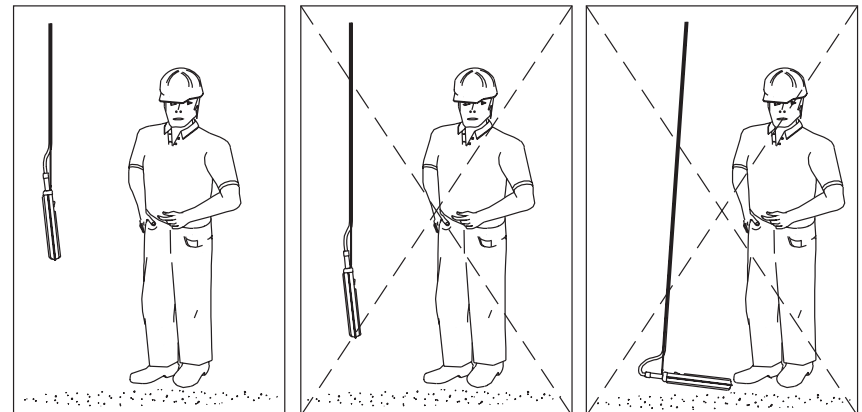

Typical Installation of Strain Relief Round Cable

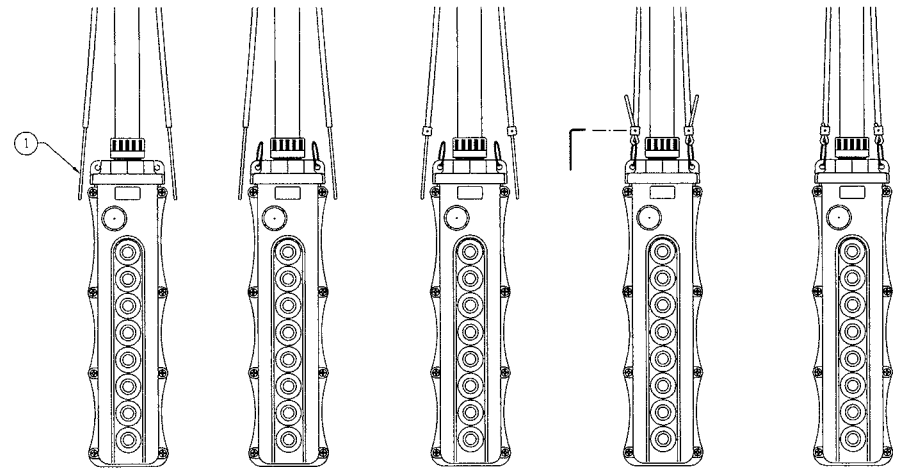
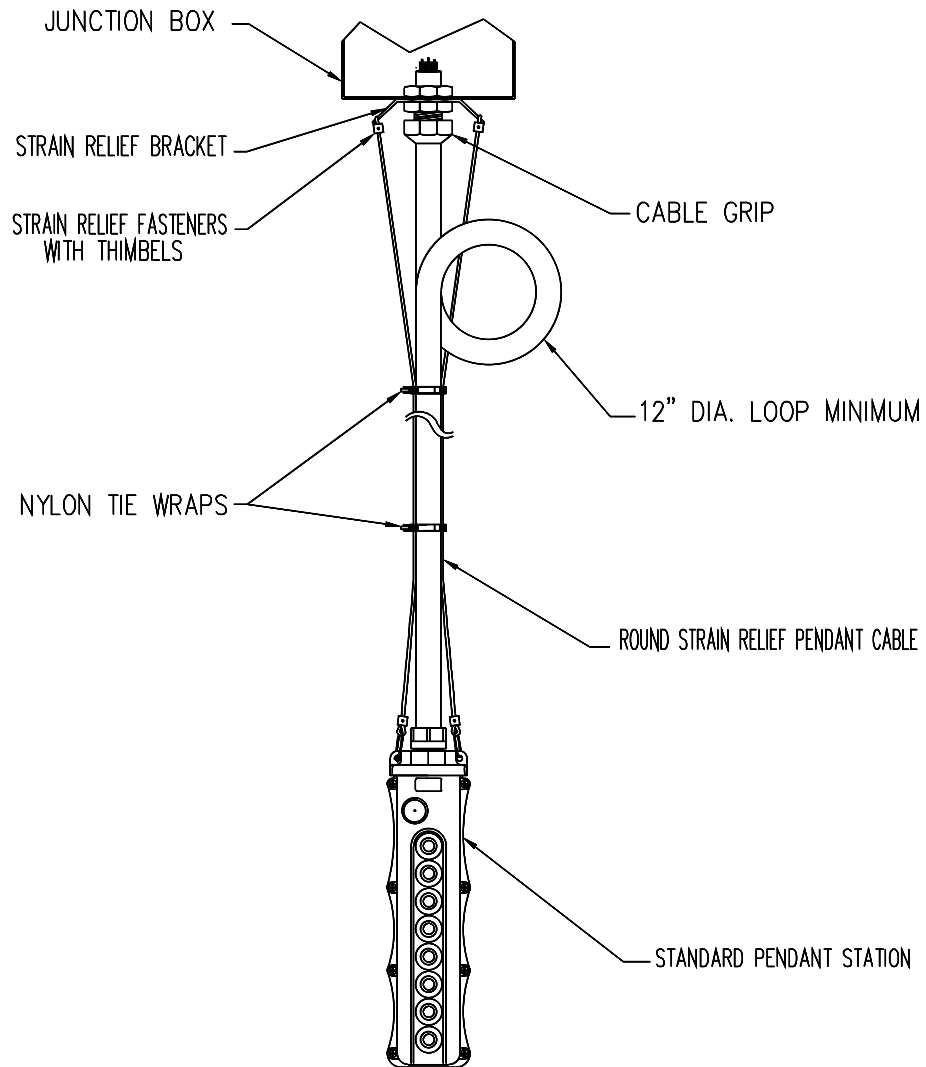

1. REMOVE INSULATION FROM STRAIN RELIEF CABLE
2. INSTALL STRAIN RELIEF SPLIT RINGS
3. INSTALL STRAIN COLLAR (w/ GRUB SCREWS)
4. THREAD STRAIN RELIEF WIRE THROUGH SPLIT RING AND BACK THROUGH COLLAR
5. TIGHTEN GRUB SCREW TO SECURE LOOP MAKING SURE STRAIN RELIEF IS INSTALLED CORRECTLY TO GIVE PULL-OUT PROTECTION
6. TRIM OFF WIRED ENDS

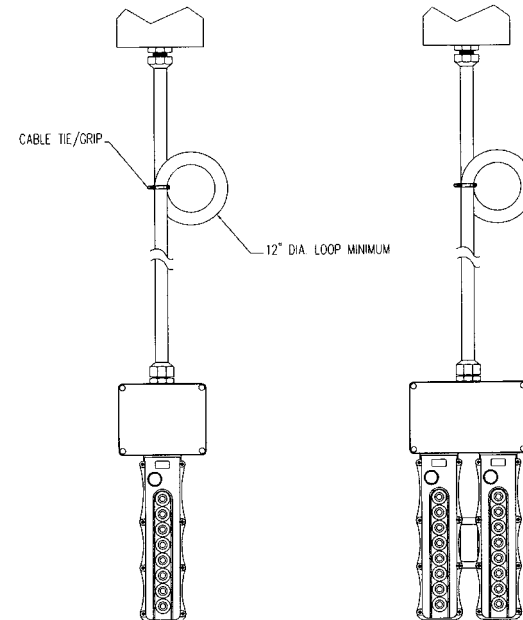

WHEN STRAIN RELIEF CABLE IS NOT AVAILABLE
 CABLE TIE INSTALLATION SHOULD CREATE
 SUFFICIENT GRIP TO HOLD THE LOOP IN PLACE DURING
 REGULAR ACTIVITY BUT ALSO ACT AS A STRAIN RELIEF
 GIVING PULL-OUT PROTECTION WHEN UNDER ABNORMAL LOAD.